

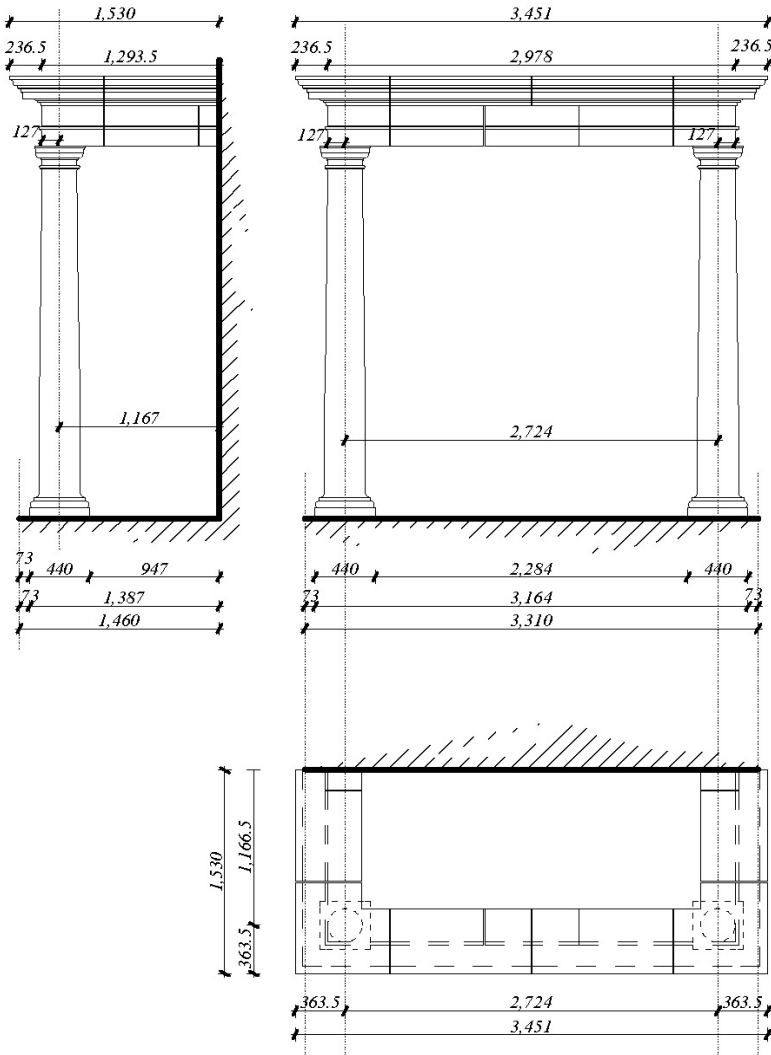

PO Box 657 Moss Vale NSW 2577
 Phone / Fax: (02) 4869 4342 || Mobile: 0412 277 292
 Email: admin@nustone.com.au

PORTICO INSTALLATION NOTES



job specific engineering details to be provided by project engineer; reo specifications and fill specifications to be approved by project engineer

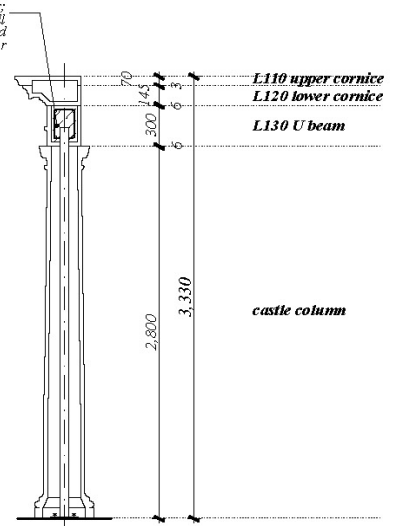

1. Quantities required of L110, L120 and L130 U Beam shown on detail drawings and specified in the component list
2. Quantities required of castle columns: 2
3. Steel specification by project engineer
4. Lifting lugs to future detail.

COMPONENT LIST

L130 U beam

Straight elements	at 685mm (trimmed from 800mm)	5 at 800mm
Straight elements	at 141mm (trimmed from 800mm)	1 at 800mm
Corner elements	at 450x450mm	2 at 450x450mm

Please note trimming to be completed on side to preserve site tolerances.

L120 lower cornice

Straight elements	at 1030mm (trimmed from 1100mm)	2 at 1100mm
Straight elements	at 832mm (trimmed from 1100mm)	2 at 1100mm
Corner elements	at 630x630mm	2 at 630x630mm

Please note trimming to be completed on side to preserve site tolerances.

L110 upper cornice

Straight element	at 1030mm (trimmed from 1100mm)	2 at 1100mm
Straight element	at 832mm (trimmed from 1100mm)	2 at 1100mm
Corner element	at 686x686mm	2 at 686x686mm

Please note trimming to be completed on side to preserve site tolerances.

Approved by
 Architect/Builder _____
 date _____